

ABSTRACT

In this paper present four quadrant speed control model is designed by using chopper to control the speed of DC motor. The designed model provide four quadrant speed control of DC motor in both direction, ie. clockwise direction, counter-clockwise direction along with braking of the DC motor. This operation will most superior in DC motor than the AC because changing the rotation of motor is difficult and complicated in AC as compare to DC. In this .The Insulated Gate Bipolar Transistor (IGBT) is used for speed control of DC motor which is very smooth in operation. The chopper circuit is designed by Insulated Gate Bipolar Transistor (IGBT) to control the speed of DC motor in both direction. The switching operation of IGBT is done by can by using Pulse Width Modulation (PWM) technique. In this designed model PWM signal can be generated by using of IC LM324 (Quad op-amp).As per the variation in the pulses motor speed will be vary. By Four Quadrant Speed control technique it is very easy to control the direction and speed of the motor. In this paper designing of speed control is verified experimentally on DC motor.

KEYWORDS:Four Quadrant Chopper, IGBT, DC motor, PWM, Voltage regulator.

INTRODUCTION

Four Quadrant DC motor are extremely used in adjustable speed drive and position control application. Their speeds below the base speed can be controlled by armature-voltage control. Speeds above the base speed are obtained by field-flux control. As speed control method for DC motors are simpler and less expensive than those for the AC motors, DC motors are preferred where wide speed range control is required. DC choppers also provide variable dc output voltage from a fixed dc input voltage. Chopper circuit are operate in four quadrant ie. Forward Motoring, Forward Braking, and Reverse Motoring and Reverse braking. This type of chopper is widely used in reversible motor drive. Insulated Gate Bipolar transistor is combination of Bipolar Junction Transistor (BJT's) and Metal Oxide Semiconductor Field Effect Transistor (MOSFET's). It carries positive attributes of BJT's and MOSFT's.

Four Quadrant Chopper

Chopper is used for conversion of fixed DC into variable DC. Operation of four quadrant chopper is shown in figure1. In the first quadrant operation power can be flow from source to load and hence, current and voltage in the first quadrant are assumed to be positive. Similarly, in second

quadrant operation voltage remain positive but change in direction of current ie. negative this condition happened when load is inductive such as a DC motor in third quadrant operation current and the voltage are both in negative but the power is positive. Similarly in four quadrant operation current is positive and voltage is negative and therefor power is negative which is shown in figure1.

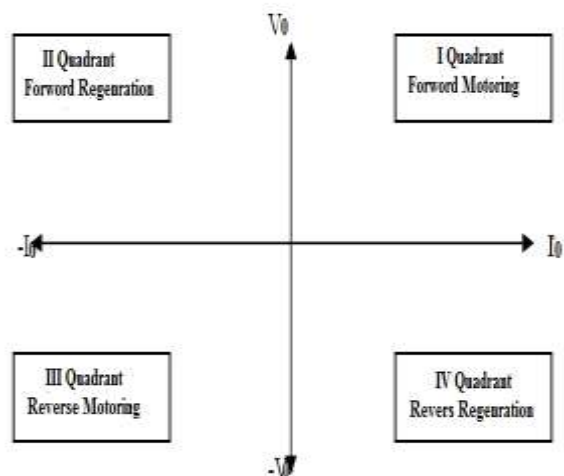

Basic operation of Four quadrant chopper

At the first quadrant current and voltage are positive then the motor can rotate in the forward direction i.e. forward motoring. If the polarity of armature current and armature voltage changing then the motor can be operated as reverse motoring i.e. (III Quadrant) and when direction of energy is reverse in II and IV Quadrant the motor can be operated as a generator braking. The chopper will give the facility of regenerative braking. The regenerative braking is caused when the energy can return to the supply and the main condition for the regenerative braking is that the EMF produced by the motor which is rotating EMF must be greater than the applied voltage so that it can flow in the reverse direction the motor can be operated at generating mode. The generating mode can be maintained over any particular duration of time only if the load is able to deliver power.

Four quadrant operation can be described by the circuit which is shown in the following figure 2.

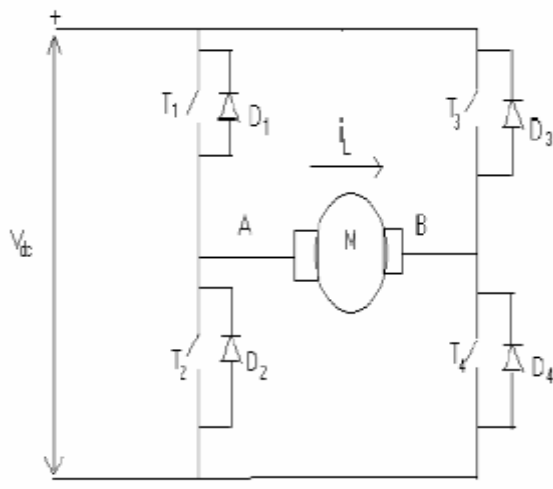

Fig1 :-Four quadrant chopper circuit

Four quadrant operations can be carried out by the four switching devices with the diode connected in anti parallel with switching diode, the motor is connected between the two arm A and B.

a) First Quadrant:-

When the supply is given to the circuit the T1 and T4 is ON, current flowing through the path, $(V_{dc+}) - T1 - \text{Load (A-B)} - T4 - (V_{dc-})$. Hence both current and voltage are positive. During this condition the inductance gets charged by positive polarity. The first quadrant operation can be achieved.

b) Second Quadrant:-

During third quadrant operation inductor gets fully charged it finds a path to get discharged during discharge the energy can be dissipated through $\text{Load(B)} - D1 - (V_{dc+}) - (V_{dc-}) - D4 - \text{Load(A)}$ since the voltage is positive and current is negative and second quadrant operation can be achieved.

c) Third Quadrant:-

When T2 and T3 are turned-on current starts to flow through path $(V_{dc+}) - T3 - \text{Load (B-A)} - T2 - (V_{dc-})$, the current and voltage are negative. The second quadrant operation can be achieved. The inductor gets charged again with the same polarity.

d) Fourth Quadrant:-

During first quadrant operation inductor gets fully charged it will find the path to discharge for that inductor changes the polarity and gets discharged through path $\text{Load(B)} - D3 - (V_{dc+}) - (V_{dc-}) - D2 - \text{Load(A)}$ in that case voltage is negative and current is positive the fourth quadrant operation can be achieved.

If we consider the power in the electrical system is given below

$$P_o = V_o * I_o \quad (1)$$

Where, P_o = Output power in the circuit

V_o = Output voltage

I_o = Output current

This gives the result that the system can allow the power flow in both directions while reversing the current and changing the polarity of the voltage, that way the motor can be operated in both directions.

Design of Circuit

Block diagram of the experimental setup is shown in the figure. Generally, switches can be used to change the direction of rotation of the DC motor. Changing the polarity of the voltage and the motor can spin in the other direction, but this idea has some disadvantages if suddenly the voltage on the DC motor is reversed during spinning. It causes a current surge that can burn out the speed controller. Hence to avoid such a type of problem we design this system in which only a single potentiometer is used for direction and speed control of the DC motor. The pot turning in one direction the motor starts spinning. Turning the pot another

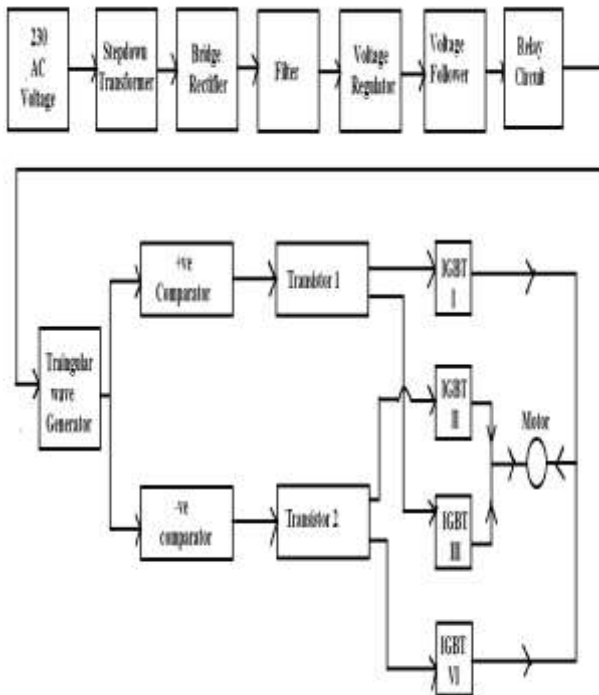

direction then motor start spinning in opposite direction and the center position of the pot is the pot is in of state forcing the motor to become slow and get stop before changing the direction of motor.

Fig 2:- Block diagram

The electronics devices are work on the 12volt dc supply hence while giving the 230volt AC supply it is necessary to step down the supply by step-down transformer (230v-12v) and this AC supply rectified in DC supply by the rectifier. The supply kit having the rectifier (Bridge rectifier), filter (Capacitor filter), voltage regulator (7812) etc. it gives the pure DC for the main operational kit. The relay circuit is use for protecting the circuit from fault or damage it will disconnect the circuit from the supply during the fault condition. The timer IC can be use in the relay circuit. In this after disconnecting the circuit from the supply the operation continues start it is not necessary to start operation from the beginning. By applying the full supply voltage to the motor in pulses. This is known as Pulse Width Modulation (PWM),this technique can be used in the system for controlling the direction and speed of the motor. Here the PWM can be generated by the LM324 Quad op-amp. Dual in line LM324 packages contain four

identical op-amps. It will operate as a mind the controlling system. That PWM pulses can be used to trigger the IGBT.

LM324 Qud Op-amp

Now a day the advancement in the comparator can be done hence the comparator is easily found such as National Semiconductor LM324 quad Op-Amps .Comparator is the modified version of Op-Amps.

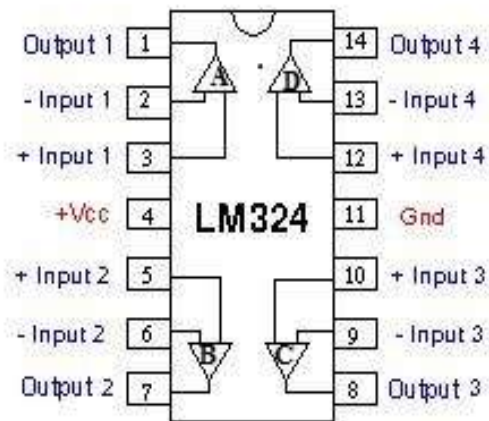

Fig 3:- Pin Diagram of LM324

LM324 Combine the four op-amp IC ie. IC-A,IC-B,IC-C and IC-D as show in the pin diagram of the IC LM324.The ramp voltage signal can be control by the potentiometer vie IC-A. Increasing and decreasing of the ramp voltage change the position of triangular wave. Op-amp IC-B use as a triangular wave generator which can provide the trigger signal to the voltage comparator. IC-C and IC-D is the voltage comparator, the reference voltage for IC-D is provided to non-inverting (+input) terminal and inverting terminal (-input) is connected to the IC-C. Due to that IC-D is triggered by a voltage which is greater than its reference voltage and IC-C is triggered by voltage less than its reference. It is not possible to trigger the both comparator at the same time because the peak to peak or maximum output level of triangular wave is less than the difference between to voltage references otherwise the all IGBT are conduct Causes the short circuit and get damage. Triggering of the IC-D and IC-C is depend upon the position of the triangular wave when triangular wave shift up then comparator IC-D trigger and triangular wave shifted down Causes comparator IC-C to trigger. When the triangular wave is between the two voltage references then no one comparator is triggered.

Pulse width modulation (PWM)

PWM is ON and OFF signal which having constant period and frequency. By adjusting the triangular wave the resultant square wave is obtaining it can be varying in the frequency or pulse width called as frequency modulation or pulse width modulation. The proportion of pulse ON time to the pulse period is called as a duty cycle. The duty cycle of pulse waveform gives the relation between input voltage and output voltage the duty cycle is the ration of ON time, t_{on} to the period T of pulse waveform is given as

$$\text{duty cycle} = t_{on} / t_{on} + t_{off} \quad (2)$$

here,

$$T = t_{on} + t_{off}$$

therefor,

$$\text{duty cycle} = t_{on} / T \quad (3)$$

Where

t_{on} = on time of the pulse waveform

t_{off} = off time of the pulse waveform

T = total period

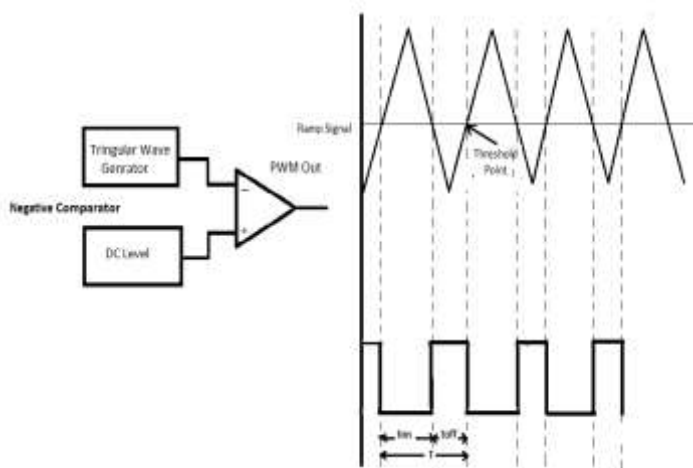

Fig 4:- waveform of positive comparator

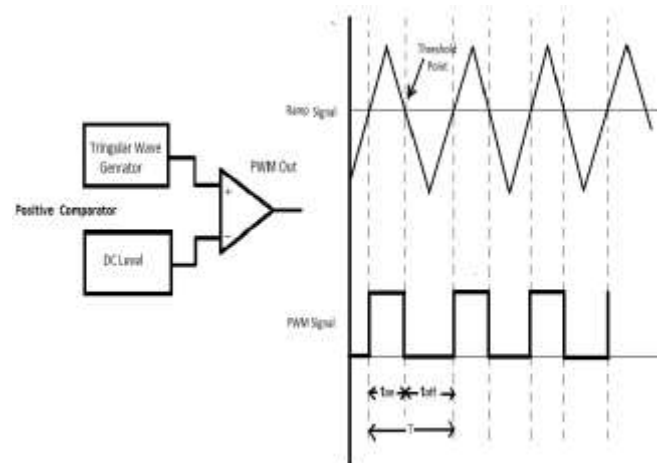

Fig 5:- waveform of negative comparator

If we change the PWM duty cycle or the PWM pulse we could change the average voltage of the motor that means the motor speed can be change by varying the PWM pulse. Short pulse means the motor runs slowly and longer pulse means motor run faster. PWM can be generated by the triangle wave generators which provide basic PWM pulse frequency and necessary ramp voltage which is may be high or low to develop the PWM signal. Ramp voltage can be continuously compared by the comparator. Ramp voltage signal is increases up to the threshold point it will turn on the comparator because non inverting input voltage of comparator is greater than the inverting input. When the ramp voltage signal is decrease means triangular wave shifted down then comparator will be turn off because the non-inverting input is less than inverting input. The generated PWM signal can be use to trigger the chopper circuit which having the four IGBT which use to control the speed and direction of the motor.

In this design we have use 12V, 300rpm DC motor whose speed and direction is going to control. The PWM signal which is generated by the LM324 comparator is provided to the IGBT. The insulated gate bipolar transistor (IGBT) combines the positive attributes of BJTs and MOSFETs. BJTs have lower conduction losses in the on-state, especially in devices with larger blocking voltages, but have longer switching times, especially at turn-off while MOSFETs can be turned on and off much faster, but their on-state conduction losses are larger, especially in devices rated for higher blocking voltages. Hence, IGBTs have lower on-state voltage drop with high blocking voltage capabilities in addition to fast switching speeds. Here, the two comparator are use they work as positive comparator and negative comparator.

Comparator gives the square wave output that output pulse voltage regulated by the zener diode which is use as a regulator that regulated output provide to the transistor it can be use as an amplifier. That transistor give the trigger pulse to the IGBT. When the triangular wave is shifted at positive cycle then the positive comparator will turn ON and negative comparator remains OFF due to the positive comparator IGBT-1 and IGBT-4 triggered and rotated the motor in forward direction similarly triangular wave is shifted to down at negative cycle positive comparator is OFF and negative comparator is turn ON which provide the trigger pulse to IGBT-2 and IGBT-3 hence the motor can rotate in the reverse direction. Speed of the DC motor it depends upon the pulses if the position of threshold point is inverses then the small pules generated and motor speed increase. By decreasing the position of threshold point large pulse will generate and motor rotate fast speed. All this operation speed control of DC motor completely depends upon the ramp voltage which can be set by the single potentiometer.

Conclusion

The four quadrant chopper circuit is design and implemented in which the speed and direction of the DC motor is control. IGBT is provide the smoother control as compare to the SCR hence, the controlling operation of motor is smoother by adjusting the PWM pulses the motor speed will be control successfully and motor will complete their operation in all four quadrant in this way the four quadrant speed control operation can be done. This system gives high reliability. Construction of whole circuit is simple and robust in nature. This type of operation generally reversible drive application for bi-direction operation of the motor.

Experimental setup

In this experiment used IGBT and LM324 quad OP-AMP are used. LM324 generate the PWM signal and it provide to the IGBT for their ON and OFF operation and because of this operation of the motor performed.



Fig 6:- Experimental setup of four quadrant operation

References

- [1] Bimal K. Bose, "Power Electronics and motion Control Technology Status and Recent Trends", IEEE transaction on industrial application Vol.29, No.5, September/October 1993, pp 902-909.
- [2] Ramakant A. Gayakwade "Op-Amp Linear Integrated Circuit" Fourth edition PHI learning private limited New delhi.2010,pp 448-449.
- [3] Bimal K. Bose, "Recent Electronics and Motor Drive Recent Progress and Perspective" IEEE transaction on industrial electronics, Vol.56, No.2, February 2009, pp 581-587.
- [4] Deodatta Y, Shingare, "Industrial and Power Electronics", Electrotech Publication, 2010, pp.2.36-2.42 and 9.19-9.20.
- [5] Prashansa B, Prashant Kumar Strategy for Four Quadrant Operation Of DC Motor Using DSPIC30F4011 "International Journal Of Recent Technology & Engineering (IJRTE) ISSN:2277-3878, vol.3 Issue-3 July 2014, pp 73-76.
- [6] Pendharkar Sameer, Trivedi Malay, Shenai Krishna "Electrothermal Simulations Punchthrough Nonpunch through IGBT's", IEEE transactions on electron devices Vol. 45, No. 10, October 1998, pp.2222-2231.
- [7] Joachima Holtz, Senior member, IEEE "Pulse Width Modulation- A survey ", IEEE Transaction Industrial Electronics, Vol. 39, No.5, December 1992, pp 410-420.

Author Bibliography

	<p>Devika R. Yengalwar(Age 22)</p> <p>I am pursuing BE.degreein Electrical Engineering (E&P), DESCOET Dhamangao Rly., From AmrawatiUniversity,India.</p> <p>Email:</p>
	<p>Samiksha S. Zade(23)</p> <p>She is pursuing BE degree in Electrical Enggineering (E&P), DESCOET Dhamandao Rly. , From Amrawati University.</p>
	<p>Dinesh L. Mute (Age 26)</p> <p>He recived BE degree from SGGSIET, Nanded and M.Tech(2nd year) from NIT Rourkela(MS)</p>

